

Extrusion Solutions for Wood-Plastic Composites

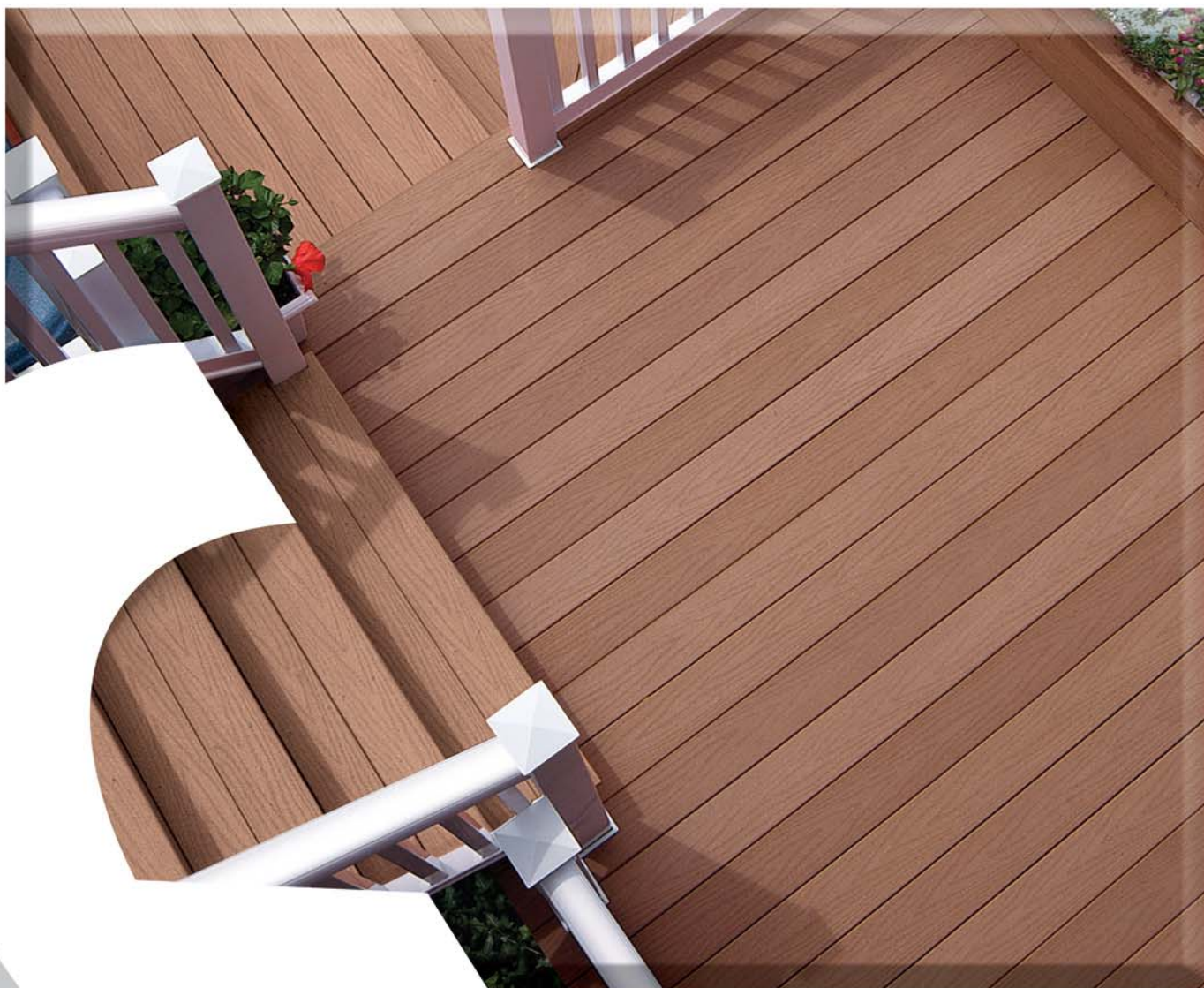

Extrusion Solutions by ENTEK



Producing high quality wood-plastic composite decking requires expertise in materials and machinery technology. ENTEK provides this and more, helping customers improve quality, increase output, and gain market share.



Wood-Plastic Composites for Outdoor Living

Wood-plastic composite decking products continue to show exponential growth in the marketplace as an alternative to traditional wood decking, and today's strong movement towards outdoor living spaces is fueling this growth.

Leading wood-plastic decking producers use ENTEK extruders, and not just because of the company's high performance co-rotating twin screw extruders. ENTEK's expertise in overall plant operations has helped decking producers make higher quality products with their materials, increase line production capacity, and grow their businesses and profitability.

If you are working with wood-plastic composites, contact ENTEK today to find out how we can help you achieve your goals of:

- easier start-ups
- cost-effective delivery of resin, wood fiber and additives to the process
- higher productivity
- higher performance
- systems integration with all key elements at your plant

More Than Just Extruders – Complete Plant Solutions

ENTEK Wood-Plastic Composite Extrusion Systems

Besides providing state-of-the-art twin-screw extruders, ENTEK offers turnkey solutions for your entire processing plant. Our engineers have helped numerous customers establish complete plant-wide operations, often from the ground up.

Whether you're looking to add an extrusion line, considering a plant expansion, or planning an entirely new production facility, ENTEK is field-proven and has the experience to help. And we do it with no strings attached – unlike other suppliers, ENTEK does not require fees or licenses for the use of its technology.

The schematic pictured below illustrates a typical layout for an ENTEK wood-plastic composite system for producing deck boards. If fiber-plastic composites are your business, we would like to talk with you. We're confident we can partner with you to improve your productivity and as a result, improve your bottom line.

- 1 Loss in Weight Feeders** for accurate formulation and steady state operations. Feeder controls are fully integrated into the extruder controls.
- 2 E-MAX™ Twin-Screw Extruders** feature segmented barrels and screws for optimization of any formulation. The co-rotating design yields excellent dispersive and distributive mixing for high throughput and consistent finished product.
- 3 Melt Pump** for pressure generation and control. Allows for combined compounding and direct profile extrusion.
- 4 Dies** can be ENTEK or customer supplied. ENTEK will supply all adapters to connect downstream equipment to the outlet of the extruder.
- 5 Cooling Tanks** use water drench cooling for maximum heat transfer. The cooling tank is closed loop with pump, filters and heat exchanger. Rollers are powered by a belt drive, helping to move the profile along and reducing stress on the profile for better dimension control.
- 6 Servo Cutters** allow for precise manual or automatic cutting of profiles. A rotary encoder compensates for fluctuations in product speed to maintain accurate cut lengths.
- 7 Surface Finishing** is highly customer specific. ENTEK will work with customers to incorporate the solution that best meets their needs.
- 8 Process Control** allows for continuous machine monitoring. Historical data can be compiled to help optimize the process and central alarming assists with troubleshooting. Data files can be used in Microsoft Excel for auto process reporting.





Drawing and photos depict a typical layout for a 103mm ENTEK system. Systems based on the 53mm, 73mm, and 133mm extruders are also available.

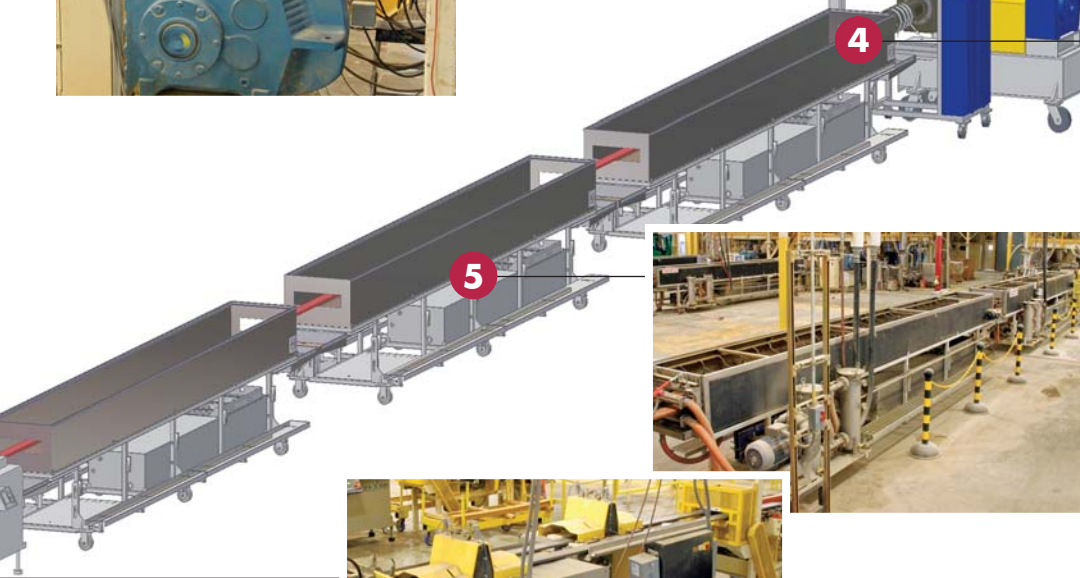
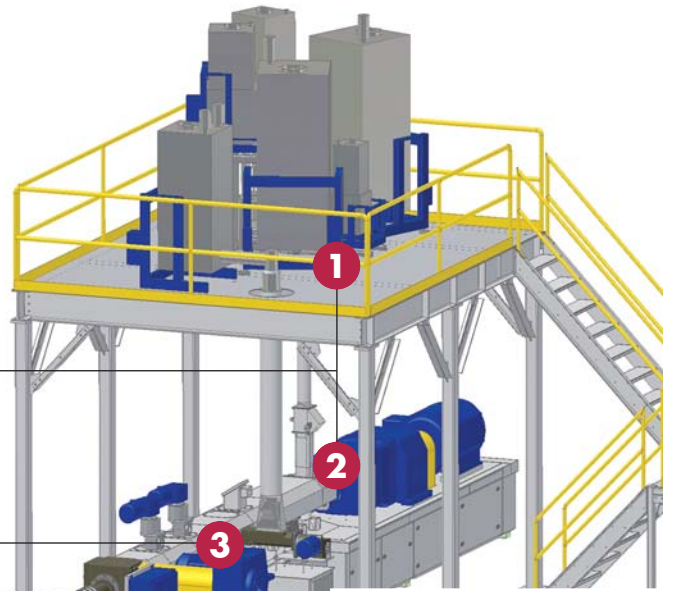



The process begins with your materials. Your formula of wood flour or other natural fiber material, along with virgin or regrind plastic needs to be tested, adjusted, and optimized, and this is where you'll immediately notice the ENTEK difference. At our in-house lab in Lebanon, Oregon, we will work with you to run comprehensive trials of your material to perfect the process.

Industry Leading Throughput

Tell us your production goals, and we'll help you choose the best ENTEK extruder for your application. When you go into production, you can be confident that ENTEK extruders feature the highest output rates in the wood-plastic composites industry. Our co-rotating twin-screws are designed for maximum throughput, and are constructed to withstand the harshest material formulations and operating conditions.

For high-volume deck and railing profiles made from HDPE or PP and wood, the E-MAX™ 103mm is an industry workhorse, achieving rates of 3,000 to 3,500 lbs/hr or better day in and day out.

Give ENTEK a Try –
Bring Us Your
Toughest
Formulation

ENTEK E-MAX™ Extruder	Throughput Rate (lbs/hr)	Throughput Rate (kg/hr)
53mm	750-1,250 lbs/hr	350-600 kg/hr
73mm	1,500-2,500 lbs/hr	675-1,125 kg/hr
103mm	3,000-4,000 lbs/hr	1,350-1,800 kg/hr
133mm	5,500-7,500 lbs/hr	2,450-3,350 kg/hr



ENTEK will help you choose the best E-MAX™ twin-screw extruder for your application, depending on your production goals.



ENTEK Advantages



You have choices when it comes to working with a twin-screw extruder supplier. Here are a few reasons to choose ENTEK:

- we don't just want to sell you a twin-screw extruder, we want to partner with you to improve your process
- we encourage you to come to us with your toughest, most difficult-to-process formulation
- our experienced team of engineers add value to your entire process, providing a variety of ways to improve your productivity
- we never require fees or licenses for the use of ENTEK technology.

The bottom line is we work with our customers tirelessly until we have met or exceeded their goals. Call us today to see how ENTEK can help you with your specific application!



Global Headquarters
ENTEK Manufacturing, Inc.
PO Box 39
250 N. Hansard Avenue
Lebanon, OR 97355 USA
Tel. 541-259-1068
FAX 541-259-8018
www.entekextruders.com



MADE IN OREGON